

# LED Lighting

## 25 LED Single Pancake Lamp



Model: L50-0042



### DIMENSIONS

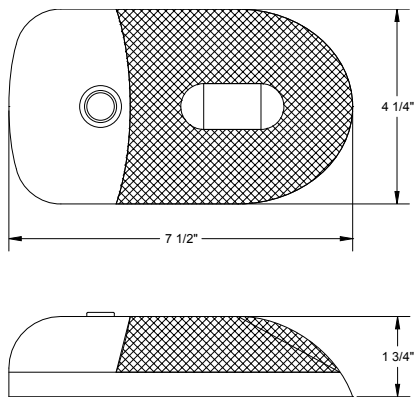

### LIGHT OUTPUT AT 8 FEET IN LUX

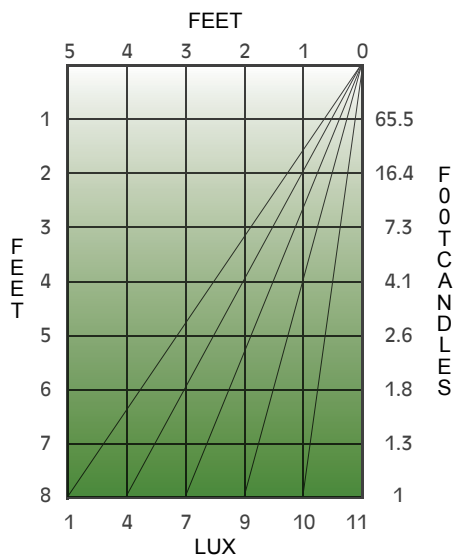

### SPECIFICATIONS

- Light source: 25 light emitting diodes; 5500 Kelvin, 88 Lumens
- Designed at: 12VDC, 0.12 Amp, 1.47 Watts

## Green|SERIES PRODUCT INFORMATION

### FEATURES

- Run 11 Green Series 25 LED Single Pancake Lamps versus 1 incandescent version from power source.
- Reduce battery power consumption by 85%.
- Bright Daylight White spectrum LEDs.
- Easy operation, one-way on/off switch.
- Compact size and fashionable assembly.
- White ABS plastic housing.
- PMMA lens.

### OTHER OPTIONS

**25 Diode Main / Reading Lamp w/ Night Light**  
Model: L26-0075

**15 Diode Auxiliary / Task Lamp**  
Model: L26-0071

**10 Diode Storage Bay Lamp**  
Model: L26-0072

**25 Diode Main / Reading Lamp - Warm White**  
Model: L50-0042-WW

**25 Diode Main / Reading Lamp w/ Night Light Warm White**  
Model: L26-0075-WW

**15 Diode Auxiliary / Task Lamp - Warm White**  
Model: L26-0071-WW

**10 Diode Storage Bay Lamp - Warm White**  
Model: L26-0072-WW

### ACCESSORIES

**Bezel** Model: L12-0096

- White ABS plastic

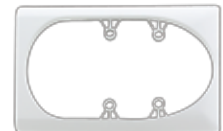

Thank you for your interest in Kaper II, Inc.

Kaper II, Inc.  
2212 1/2 Parrott Way  
Kelso, WA 98626, USA

tel: 800-336-2011  
fax: 360-423-0785  
www.kiigreenseries.com

### PRODUCT RECOMMENDATION

To reduce the risk of fire, burns, or injury, use lights only in the manner intended by Kaper II. Should you have questions regarding your installation, please contact Kaper II before applying power.